

COOKTOP

c o l l e c t i o n

Instructions for Use and Warranty Details

Gas Cooktops

- CH24 - 60cm White
- CH25 - 60cm Stainless Steel
- CH26 - 60cm Black
- CH35 - 90cm Stainless Steel
- CH84W - 60cm White - Flame Failure
- CH85S - 60cm Stainless Steel - Flame Failure
- CH86B - 60cm Black - Flame Failure
- CH95S - 90cm Stainless Steel - Flame Failure



KLEENMAID
THE WORLD'S BEST





Congratulations on the purchase of your new Kleenmaid appliance. This appliance has been designed and manufactured to give you years of reliable performance. For best results, carefully read the instructions on how to install your new appliance. Correct installation will avoid delays and unnecessary service calls.

Once installation is complete, read this booklet and get to know the controls and the features of your new appliance.

If you need further information call our

Customer Call Centre
1 800 072 144.

We reserve the right to alter the specifications with no influence on the operation of the appliance. This instruction manual cannot be reason for a claim.

INSTALLATION

CAUTION:

- ✓ This appliance must be installed in accordance with these installation instructions and the requirements of the local gas authority or the appropriate installation code issued by the A.L.P.G.A. and A.G.A. (Refer to AG601 Code), or the Building Authority requirements.
- ✓ This appliance shall only be serviced by authorized personnel.

WARNING:

- ✓ This appliance is to be installed only by an authorised person.
- ✓ This appliance must be used only for the task it has explicitly been designed for, that is for cooking foodstuffs. Any other form of usage is to be considered as inappropriate and therefore dangerous.
- ✓ Do NOT place combustible materials or products on this appliance at any time.
- ✓ Do NOT spray aerosols in the vicinity of this appliance while it is in use.

CLEARANCES:

Installation clearances and protection of combustible surfaces shall comply with section 5.12 of AG 601 - 1995.

Figure 1

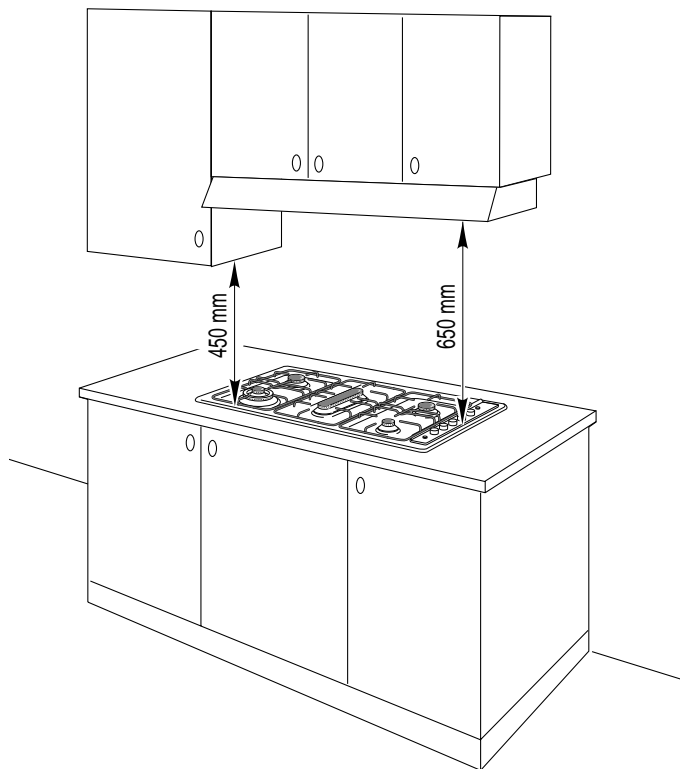

NOMINAL GAS CONSUMPTION AND INJECTOR SIZES (Table 1):

Test Point Pressure (kPa)	Natural Gas		LPG	
	1.0		2.75	
Burner	Injector Orifice [mm]	Gas Consumption [MJ/h]	Injector Orifice [mm]	Gas Consumption [MJ/h]
Simmer	0.70	2.4	0.47	2.9
Semi-rapid no.1	0.90	4.0	0.60	4.7
Semi-rapid no.2	1.15	6.5	0.76	7.5
Rapid	1.35	9.3	0.83	9.0
Wok burner	1.45	11.0	0.90	10.4
Fish warmer	1.45	11.0	0.90	10.4

(Note: Gas type sticker and data plate are attached to the underside of the base of the appliance.)

The installation shall comply with the dimensions in Figures 2 and 3, bearing in mind that:

- ✓ A minimum clearance of 20 mm has to be kept between the bottom of the cooking hob and the top of an appliance or a shelf.
- ✓ A partition between the base of the hob and the cupboard below should be fitted 100 mm below the workbench surface if the cupboard is to be used for storage.
- ✓ Overhead clearances - In no case shall the clearance between the highest part of the hob and a range hood be less than 600 mm, or for an overhead exhaust fan, 750 mm. Any other downward facing combustible surface less than 600 mm above the highest part of the hob shall be protected for the full width and depth of the cooking surface area in accordance with Clause 5.12.1.2 of AG 601. However, in no case shall this clearance to any surface be less than 450 mm.

- ✓ Side clearances - Where the dimension from the periphery of the nearest burner to any vertical combustible surface is less than 200 mm, the surface shall be protected in accordance with Clause 5.12.1.2 of AG 601 to a height of not less than 150 mm above the hob for the full dimension (width or depth) of the cooking surface area.
- ✓ Protection of combustible surfaces - AG 601 Clause 5.12.1.2 specifies that where required protection shall ensure that the surface temperature of the combustible surface does not exceed 50 °C above ambient. The fixing of 5 mm thick ceramic tiles to the surface or attaching fire resistant material to the surface and covering with sheet metal with minimum thickness of 0.4 mm would satisfy this requirement.

DIMENSIONS (Table 2):

**Models: CH24 - CH25 - CH26
CH84W - CH85S - CH86B**

(Note: Also refer to Figure 2 side)

General Dimensions	
Width	580 mm
Depth	500 mm
Depth Below Mounting Surface	30 mm
Cut-out Dimensions	
Width	560 mm
Depth	480 mm

Figure 2

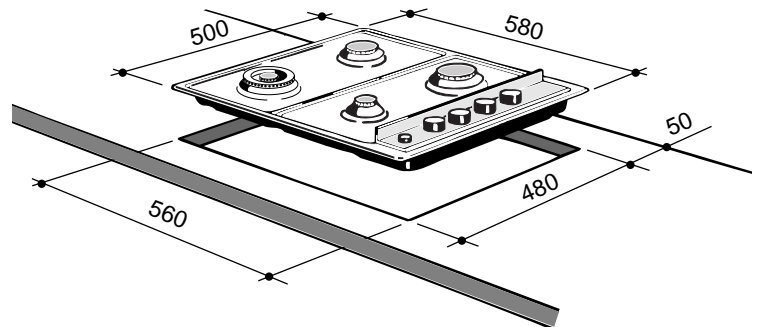

DIMENSIONS (Table 3):

Models: CH35 - CH95S

(Note: Also refer to Figure 3 side)

General Dimensions	
Width	860 mm
Depth	500 mm
Depth Below Mounting Surface	30 mm
Cut-out Dimensions	
Width	840 mm
Depth	480 mm

Figure 3

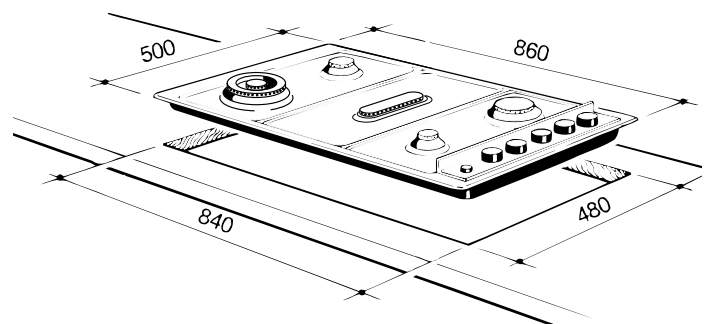

INSTALLATION

(Refer to Figures 4 and 5):

1. Spread out the gasket "C" over the workbench at the edge of the cut out taking care to overlap the gasket at the corners.
2. Slot in the cooking hob into the cut out of the workbench and locate it correctly.
3. Adjust the clamps "A" and tighten the screws "B" until the hob is firmly secured.
4. Using a sharp tool, trim any excess gasket which protrudes from the edge of the hob.
5. Assemble the three piece burners. Take care to properly locate the assembled burner on the burner base.

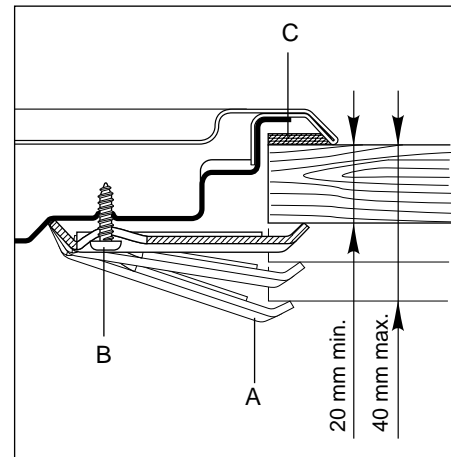

Figure 4

GAS SUPPLY:

- ✓ This appliance is suitable for use with Natural Gas or LPG. (Check the "gas type" sticker attached to the appliance).
- ✓ For Natural Gas models the gas supply is connected to the pressure regulator which is supplied with the appliance. Adjust the regulator to obtain a test point pressure of 1 kPa with the two largest burners operating.
- ✓ For LPG models connect the gas supply directly to the appliance inlet connection and ensure that the supply pressure is regulated to 2.75 kPa.
- ✓ Do NOT force the "elbow" rotation prior to loosening the nut.
- ✓ Do NOT over tighten the nut at the "elbow".

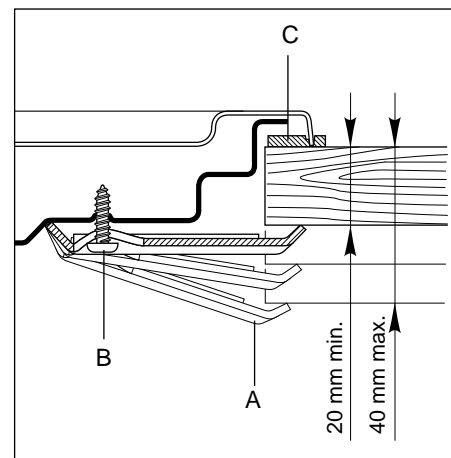
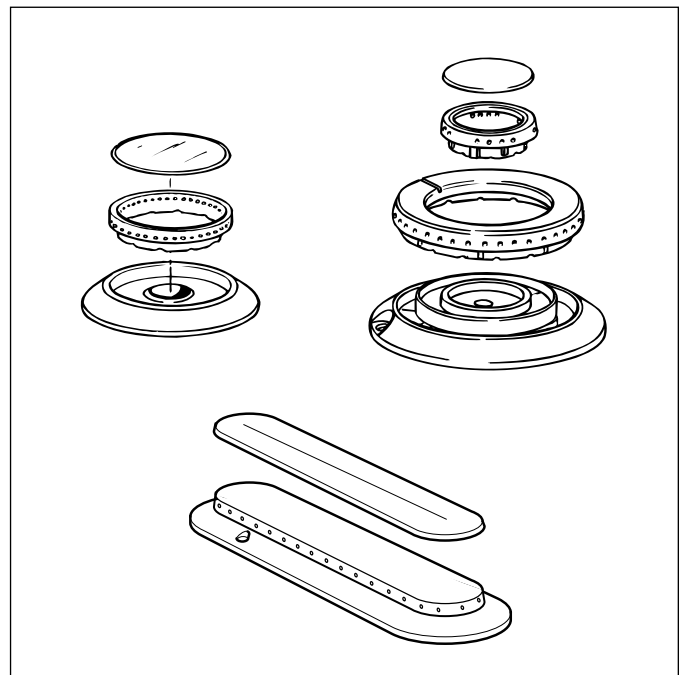

Figure 5

1. After connecting the gas supply, check the piping and connections for leaks using a soap and water solution. The presence of bubbles indicates a leak, tighten or replace connections as appropriate.
2. Adjust the test point pressure or supply pressure to the value which is appropriate for the gas type.
3. Turn on the appliance gas controls and light each burner. Check for a well defined blue flame without any yellow tipping. If any abnormality is evident then check that the burner cap is located properly and the injector nipple is aligned correctly.
4. Check the minimum burner setting by quickly rotating the gas control knob from the maximum to the minimum position, the flame must not go out. If adjustment is required carry out the "minimum burner setting adjustment" procedure described below.
5. If satisfactory performance cannot be obtained isolate the appliance and contact the local gas authority for advice and assistance.



INJECTOR REPLACEMENT:

This appliance is suitable for use with Natural Gas or LPG. (Check the "gas type" sticker attached to the appliance.) The nominal gas consumption and injector size details are provided in Table 1 on page 3.

To replace injectors

1. Remove the knobs and ignition push button
2. Unscrew the "A" screw in Figure 6
3. Remove the control panel "B" in Figure 6
4. With a wrench "C" replace the injectors "J" with those suitable for the gas to be used (see Figure 7).

Figure 6

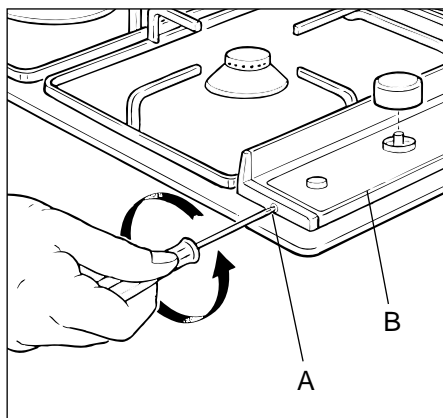
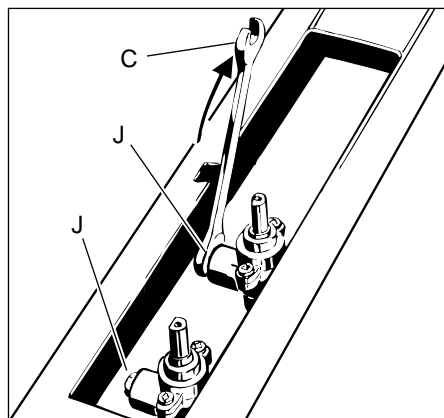

Figure 7



MINIMUM BURNER SETTING ADJUSTMENT:

To regulate the flame follow the instructions below:

- Light the burner
- Set the cock valve to minimum

On gas valves provided with adjustment screw in the centre of the shaft (fig. 8a):

- Using a screwdriver with max. diameter 3 mm, turn the screw inside the tap until the correct setting is obtained.

On gas valves provided with adjustment screw on the valve body (fig. 8b):

- Turn the screw "A" to the correct setting with a screwdriver.

Figure 8a

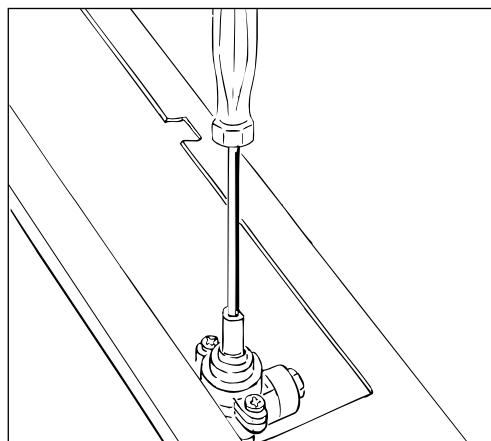
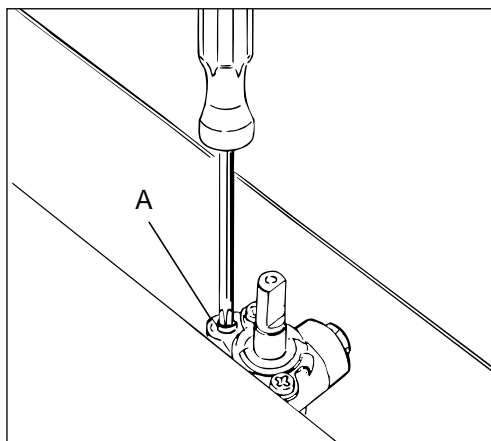

Figure 8b



ELECTRICAL REQUIREMENTS:

WARNING:

- ✓ THIS APPLIANCE MUST BE EARTHED.

CAUTION:

- ✓ Ensure that the power outlet is properly earthed before connecting the appliance.
- ✓ Disconnect power before servicing the appliance.

The appliance is provided with a standard 240VAC three pin plug and power cable (3X0.75 mm²).

The wires in the power cable are coloured in accordance with the following code: Green/Yellow = Earth, Blue = Neutral, Brown = Active.

If the colours of the wires in the power cable to the appliance do not correspond with the coloured markings identifying the terminals in the junction terminal, proceed as follows:

1. The wire which is coloured green and yellow must be connected to the terminal marked **E** (Earth) or coloured Green.
2. The wire which is coloured blue must be connected to the terminal marked **N** (Neutral) or coloured Black.
3. The wire which is coloured brown must be connected to the terminal marked **L** (Live) or **A** (Active) or coloured Red.

WIRING DIAGRAM:

Figure 9

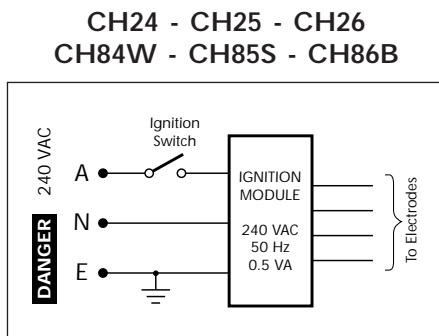
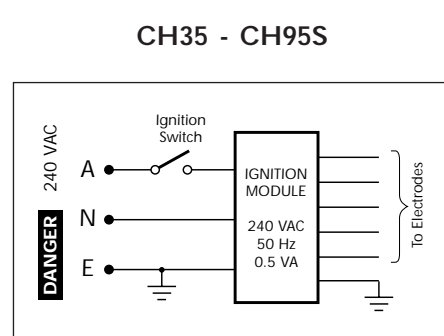

Figure 10



REPLACEMENT OF IGNITION MODULE/ELECTRODES/GAS COCKS:

1. Turn off and disconnect gas supply and electricity.
2. Lift off trivets and burner heads, and pull off igniter and control knobs.
3. Undo the screws "B" and remove the clamps "A" shown in Figure 4 and remove the hob.
4. Remove screws securing the top of the hob to the base pan and lift it off.
5. To replace the electrode, unhook the locking spring and remove the electrode and cable.
6. To remove the igniter module, disconnect the electrodes, power and igniter switch wires, undo the two retaining screws and remove the module.
7. To remove the gas cock undo the two screws which secure it to the gas manifold. On re-assembly ensure that the injectors are aligned with the burner venturi.
8. Reassemble in reverse order
9. Check all connections for gas leaks with soapy water (including gas cocks if they have been removed).

GAS COCK LUBRICATION:

1. Turn off gas supply and disconnect electricity.
2. Remove the knobs and ignition push button
3. Unscrew the "A" screw in Figure 6
4. Remove the control panel "B" in Figure 6
5. Unscrew the two screws on top of the gas cock
6. Lift out the valve cone, clean it with solvent and re-grease it with high temperature grease
7. Replace the valve cone, move it around and remove excess grease. Remove it once again and check that internal holes or galleries are not blocked.
8. Replace and reassemble in reverse order.
9. Check for gas leaks with soapy water.

USE and CARE

CAUTION:

- ✓ This appliance must be used only for the task it has explicitly been designed for, that is for cooking foodstuffs. Any other form of usage is to be considered as inappropriate and therefore dangerous. Do not use this appliance as a space heater.
- ✓ Do NOT place combustible materials or products on this appliance at any time.
- ✓ Do NOT spray aerosols in the vicinity of this appliance while it is in use.
- ✓ Before using for the first time, clean the cooktop with warm soapy water.
- ✓ Use the coffee pot support to ensure that small cooking utensils are stable.

Figure 11

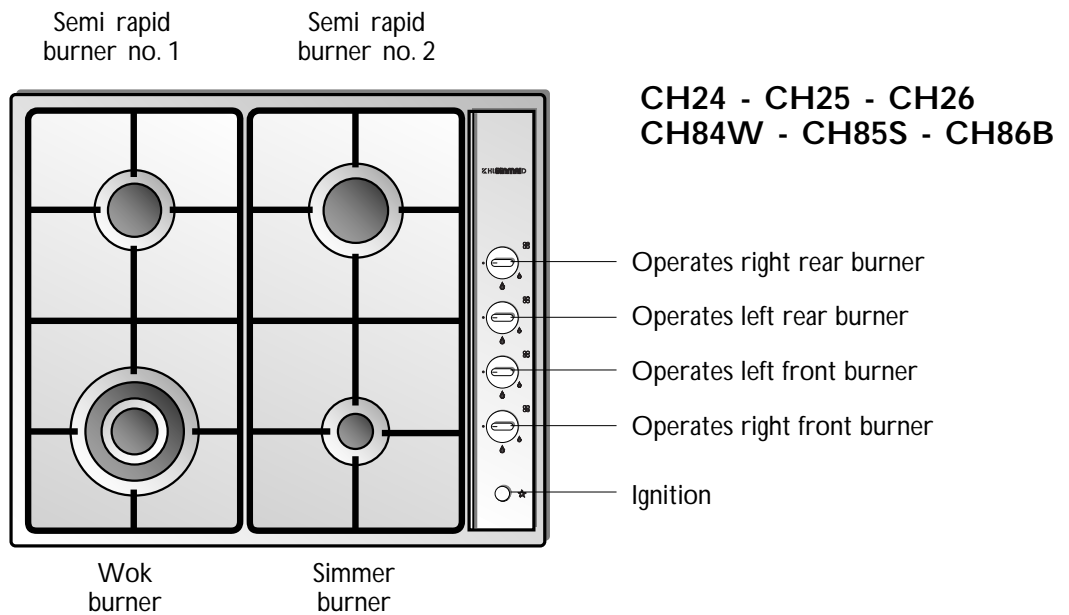
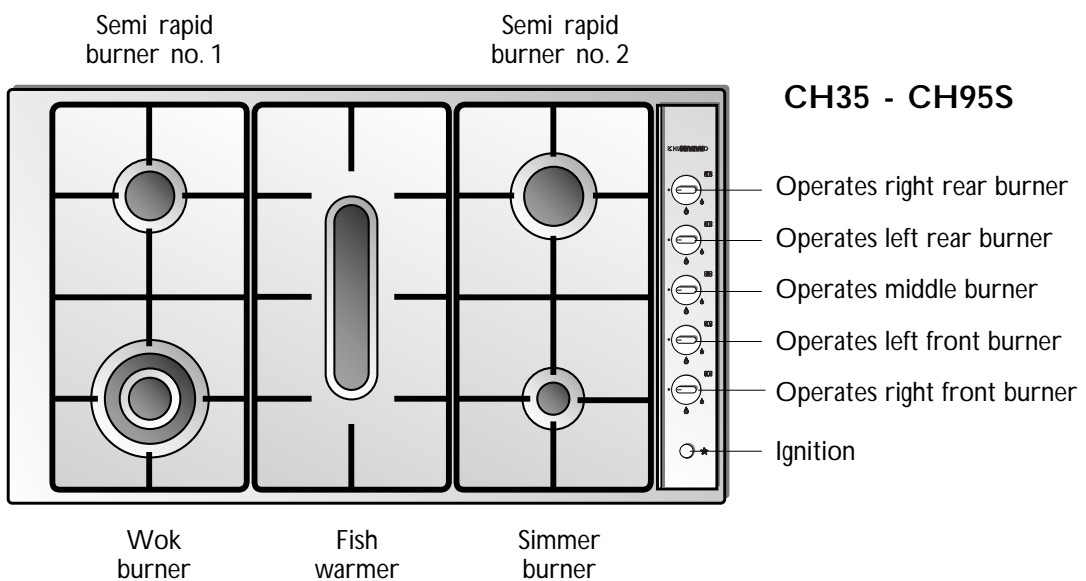



Figure 12



- ✓ Check that the electricity is switched on to allow spark ignition.
- ✓ Make sure that all controls are turned to zero.
- ✓ The gas flow to the burner is controlled by a knob operating on a safety tap. You control the flow by turning the knob indicator to line up with the following symbols:

symbol ● : Off

symbol  : full on (nominal rate)

symbol  : reduced rate

- ✓ To ignite automatically, simply push the required knob down and turn it to maximum, then press ignition continuously until the burner lights. When the flame is lit, you can control the temperature by the knob.
- ✓ To switch off, turn the knob clockwise until you hear the safety click.
- ✓ Note that, if you are using a burner at the minimum setting, you turn the knob clockwise past the maximum setting before reaching the off position.

To ignite the burners with flame failure device:

1. Turn the knob counter-clockwise to the "full on" position, then maintain this pressure
2. Press ignition continuously until the burner lights.
3. Wait for about 10 seconds after the gas burner has been lit before letting go of the knob (security valve activation delay)
4. You can control the temperature by the knob.

If the burner flame should go out for some reason, the safety valve will automatically stop the gas flow.

COOKING HINTS FOR GAS HOBS

- ✓ The burners are different sizes, and can be used in different ways.
- ✓ The largest can be used for boiling, to seal meat or foods that are cooked quickly, and the smallest for stews and sauces.
- ✓ Always ensure that you use the correct size of saucepan.
- ✓ For fast boiling, make sure the flame just reaches the edge of the pan. Flames going up the side of the pan means wasted heat and the contents of the pan will take longer to boil.

Figure 13

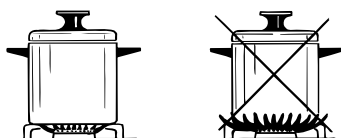

CORRECT USE OF DOUBLE-RING BURNER

- ✓ The flat-bottomed pans are to be placed directly onto the pan-support.
- ✓ To use the WOK you need to place the proper stand in order to avoid any faulty operation of the wok burner.

Figure 14

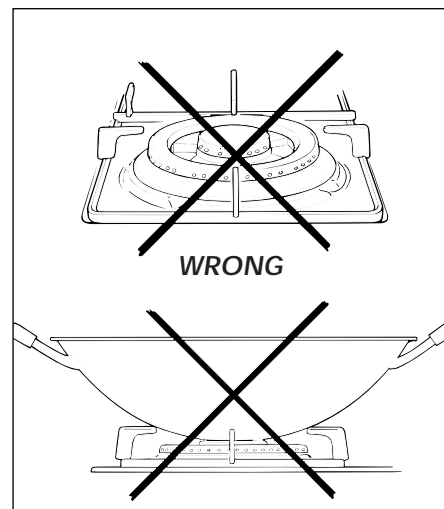
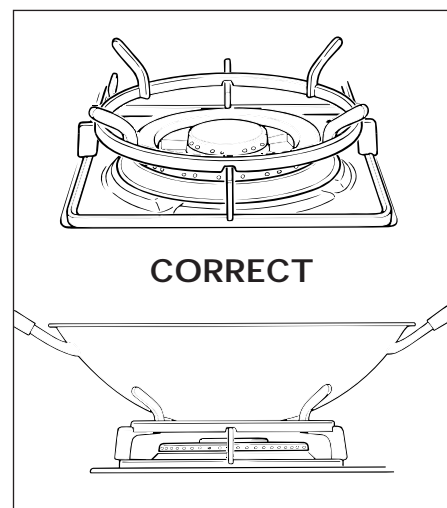

Figure 15



CLEANING AND MAINTENANCE

GENERAL ADVICE

- ✓ It is advisable to clean when the appliance is cold and especially when cleaning the enamelled parts.
- ✓ Avoid leaving alkaline or acidic substances (lemon juice, vinegar, etc.) on the surfaces.
- ✓ Avoid using cleaning products with a chlorine or acidic base.

ENAMELLED PARTS

- ✓ All of the enamelled parts must be washed only with a sponge and soapy water or with non-abrasive products. Dry, preferably, with a soft cloth or chamois.

STAINLESS STEEL

- ✓ Clean with a suitable product. Always dry fully with a soft cloth or chamois.

BURNERS AND RACKS

- ✓ These parts may be removed and washed with suitable products.
- ✓ The burners and their caps must be well dried after cleaning and put back perfectly into their slots. It is very important to verify the positioning of the burner-caps because a misplacing in their slots can cause serious damage.
- ✓ In the appliances with electrical ignition for the burners, verify that the electrode is always cleaned well to permit a regular spark.

SERVICE AND MAINTENANCE

If the ignition spark fails to operate or does not light the gas check the following items before calling the authorized service agent:

- ✓ Burner is reassembled and located correctly.
- ✓ Spark electrode and white ceramic are clean and dry.
- ✓ 240 VAC power supply is connected.

Contact the local gas utility or the authorized service agent if:

- ✓ You can smell gas when all burners are turned on.
- ✓ The burners do not remain alight at the minimum marked setting
- ✓ The burner flame is yellow or emits an unusual odour

Note that a bi-annual inspection of the appliance by an authorized service agent or your local gas utility will ensure many years of trouble free operation of your appliance.

WARRANTY AND SERVICE

DOMESTIC WARRANTY - FULL FIVE YEAR WARRANTY

In addition to all statutory rights which you, the Consumer, have under the relevant laws in respect of this appliance, during the first five years of ownership as the original purchaser of this Kleenmaid appliance, we guarantee that any fault caused by faulty material or workmanship becoming apparent will be rectified free of charge for parts and labour, provided that all service is performed during normal working hours by Kleenmaid or their designated Agents. Where the appliance is installed outside the normal servicing area of the above, the Purchaser must pay for the cost of transporting the appliance to and from the Agent or the Agent's travelling cost to and from the Purchaser's home.

COMMERCIAL WARRANTY - ONE YEAR WARRANTY

When this appliance is installed in a commercial application, you, the Consumer, have under the relevant laws in respect of this appliance, during your first one year of ownership as the original purchaser of the Kleenmaid appliance, we guarantee that any fault caused by faulty material or workmanship becoming apparent, will be rectified free of charge for parts and labour, provided that all service is performed during normal working hours by Kleenmaid or their designated Agents. Where the appliance is installed outside the normal servicing area of the above, the Purchaser must pay for the cost of transporting the appliance to and from the Agent or the Agent's travelling cost to and from the Purchaser's home.

WHAT THESE WARRANTIES DO NOT COVER

We are not responsible for any damage or malfunction unless caused by a defect in material or workmanship. This includes but is not limited to abuse, misuse, improper installation and transportation damage. We are not responsible for any consequential damages from any malfunction.

WARRANTY DOES NOT COVER REPLACEMENT OF LIGHT GLOBES OR GLASS BREAKAGE DUE TO IMPACT

In case of fractured glass do not use your appliance.

WARRANTY REGISTRATION

Please complete the enclosed warranty card and post it to us or phone our Customer Call Centre.

SERVICE ASSISTANCE

To assist you when phoning our Customer Call Centre number to arrange a service call please complete the following details and have them ready when you call.

Model Number:.....

Date of purchase:.....

Kleenmaid Store purchased from:.....

Date of installation:.....

**KLEENMAID CUSTOMER CALL CENTRE
CONTACT NUMBER
1 800 072 144**

Other products in Kleenmaid's
range of world's best appliances:

Washers

Dryers

Vacuum Cleaners

Dishwashers

Cooktops

Rangehoods

Ovens

Refrigerators

Sinks & Taps

**For sales information on the full range of quality
kitchen and laundry appliances, phone 13 13 08**

Kleenmaid Head Office:

PO Box 5560, Maroochydore South, Queensland 4558